

| | |
|---|--------------------------------|
| Subject: WHITE OR BLUE SMOKE FROM TAIL PIPE AFTER LONG IDLE PERIOD | Bulletin No: 01-002/11 |
| | Last Issued: 04/21/2011 |

BULLETIN NOTE

- This bulletin supersedes the previous bulletins 01-004/10 issued on 01/07/10, 02/17/10 and 08/18/10 and 01-002/11 issued 01/12/11 and 02/23/11. The INSPECTION PROCEDURE, REPAIR PROCEDURE, PART(S) INFORMATION and WARRANTY INFORMATION have been revised.
- For 2006-2007 Mazdaspeed6 vehicles with this concern, refer to TSB 01-001/11 ("WHITE OR BLUE SMOKE FROM TAIL PIPE AFTER LONG IDLE PERIOD").

APPLICABLE MODEL(S)/VINS

2007-2009 CX-7 vehicles with VINs lower than JM3ER****9*224013 (produced before July 1, 2008)

2007-2009 Mazdaspeed3 vehicles with VINs lower than JM1BK****9*187397 (produced before July 1, 2008)

DESCRIPTION

Some customers may experience white/blue smoke from the exhaust pipes after long idle periods or while driving at slow speeds in heavy traffic.

This condition may be the result of insufficient crank case ventilation, resulting in oil leakage past the exhaust turbine shaft seal.

Other possible causes (determined by reviewing the vehicle's maintenance records) that should be corrected at the owner's expense prior to performing this bulletin are:

- Engine oil viscosity break down due to insufficient oil change(s).
- Usage of lower than 5W-30 viscosity engine oil.

NOTE:

- This bulletin is not applicable to vehicles with a prior turbocharger replacement using a "C" level or later part number (i.e. L3Y*-13-70ZC).
- The oil change program as described in the prior service bulletins under the same subject, is no longer in effect.
- If the turbocharger is diagnosed with impeller damage caused by contact with the housing (as described in the Inspection Procedure), this bulletin is not applicable.

Customers having this concern should have their vehicle repaired according to the following repair procedure.

INSPECTION PROCEDURE

If the proper oil change intervals using 5W-30 have been performed, repair the vehicle using the following repair procedure.

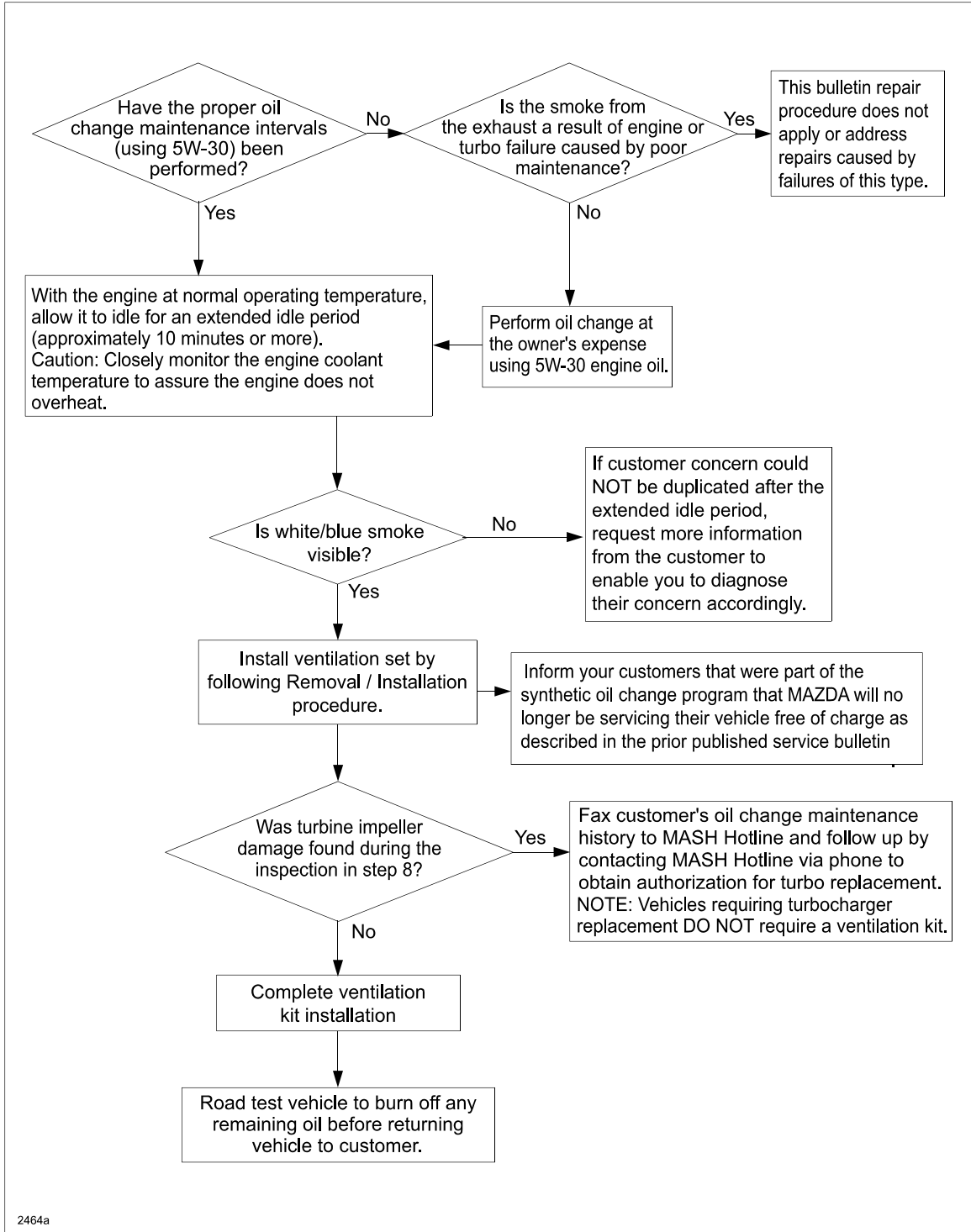

REPAIR PROCEDURE

VENTILATION SET REMOVAL:

Replace the cylinder head cover (A), ventilation hose (B), engine hanger (C), air pipe (D), vacuum hose (E) and plug (F) (all components included in the Ventilation Set).

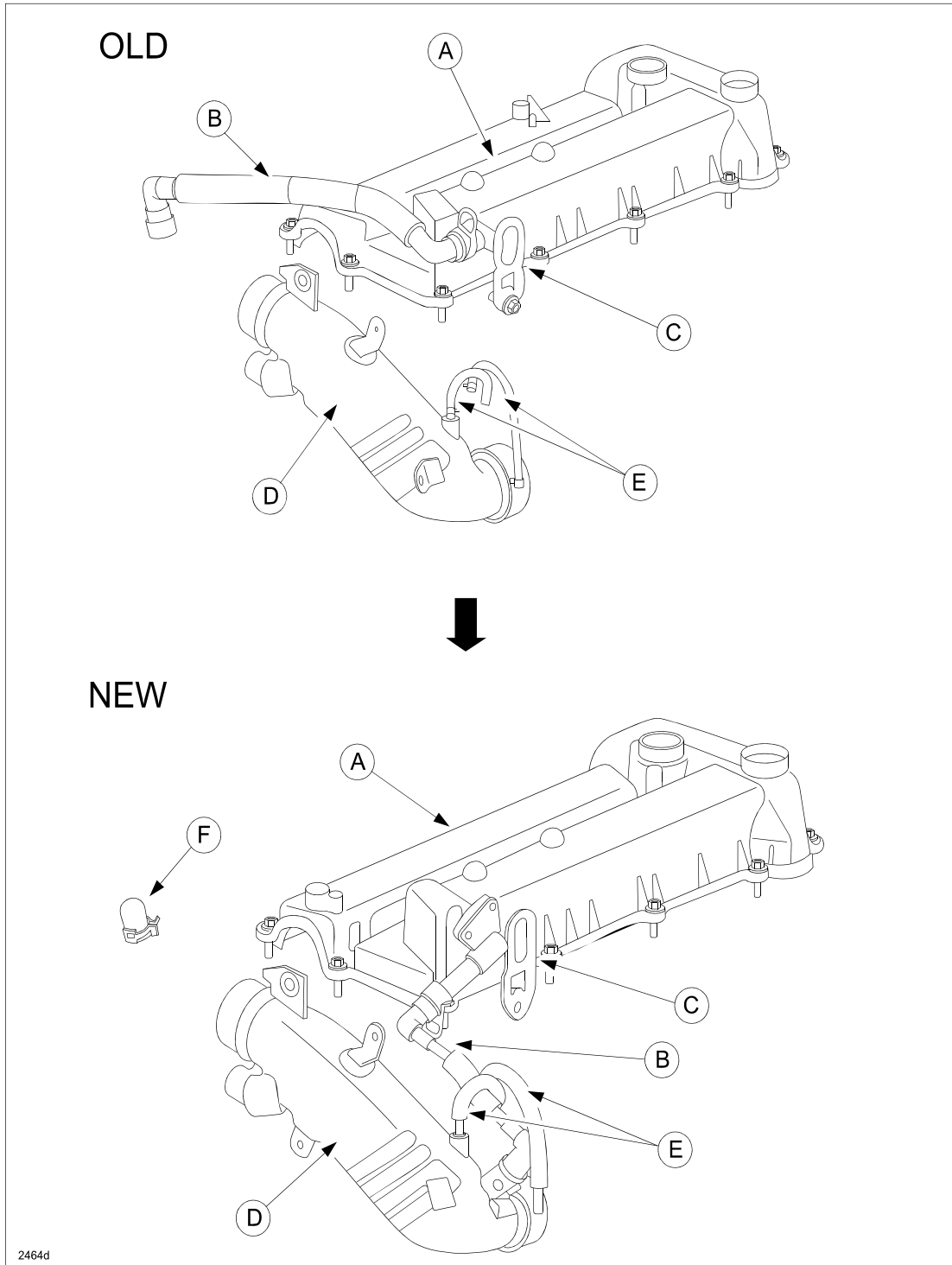

WARNING: Perform this repair procedure while the engine is cold. A hot engine can cause severe burns.

1. Record the customer's pre-set radio stations.
2. Remove the battery cover.
3. Disconnect the negative battery cable.
4. Remove the air cleaner.

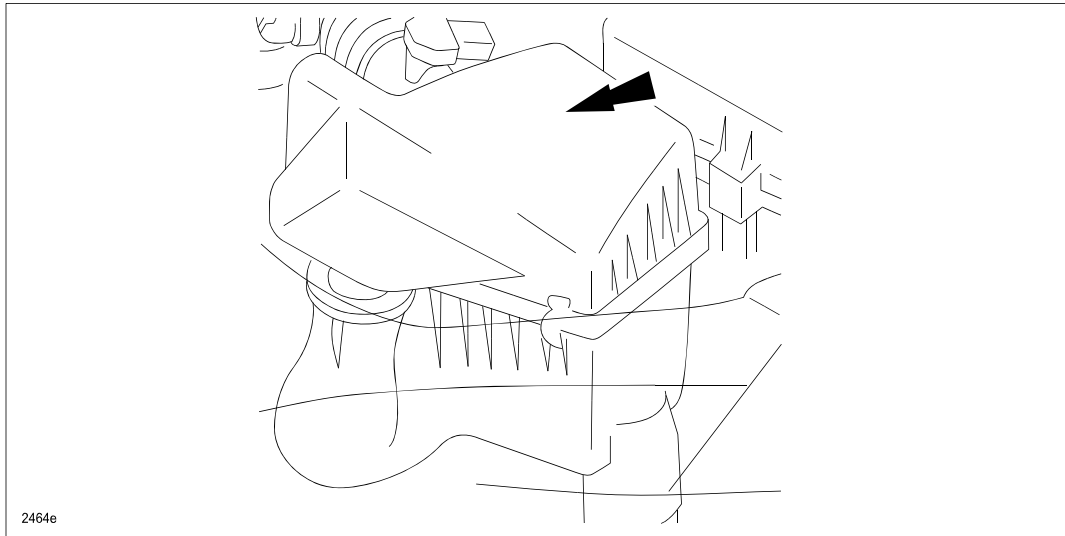

5. Remove the battery clamp, battery and battery tray.
6. Remove the intercooler cover and pull out the intercooler.

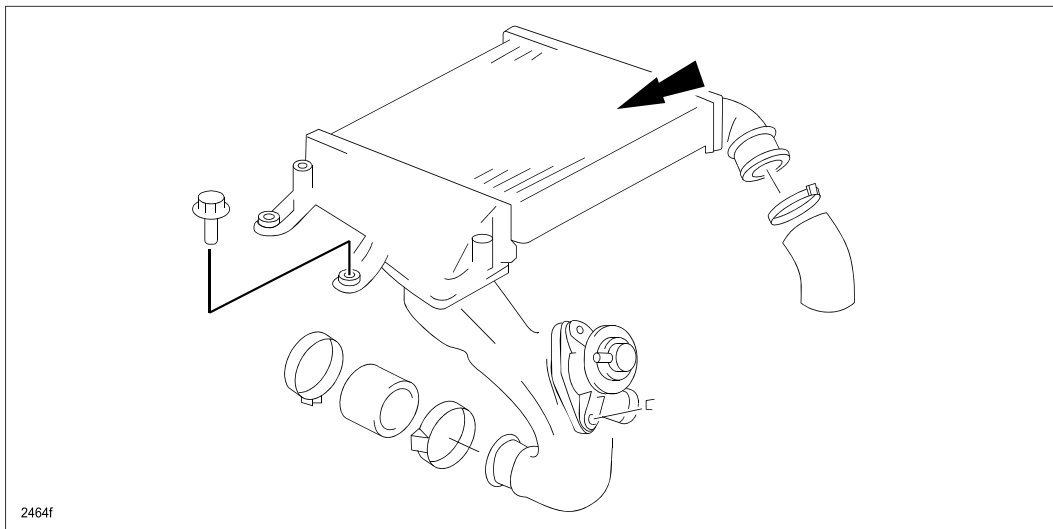

7. Remove the air pipe (A) with vacuum hose (B).

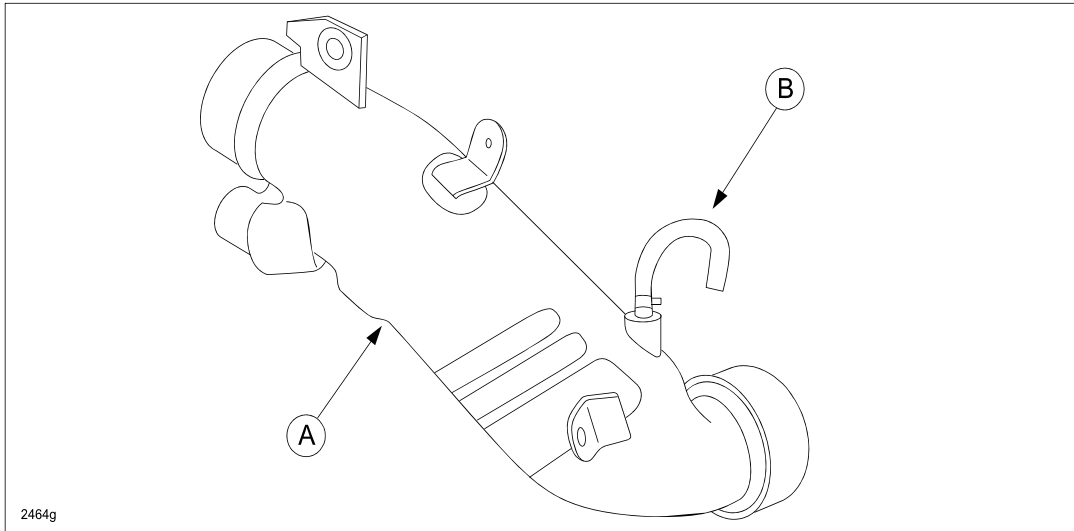

8. Inspect turbocharger for impeller contact damage due to bearing failure.

- If impeller damage is found, discontinue the ventilation kit installation procedure. Contact the Technical Assistance Hotline for turbocharger replacement authorization.
- If impeller damage is not found, proceed to next step.

NOTE: Vehicles requiring turbocharger replacement DO NOT require a ventilation kit.

9. Remove the vacuum hose.

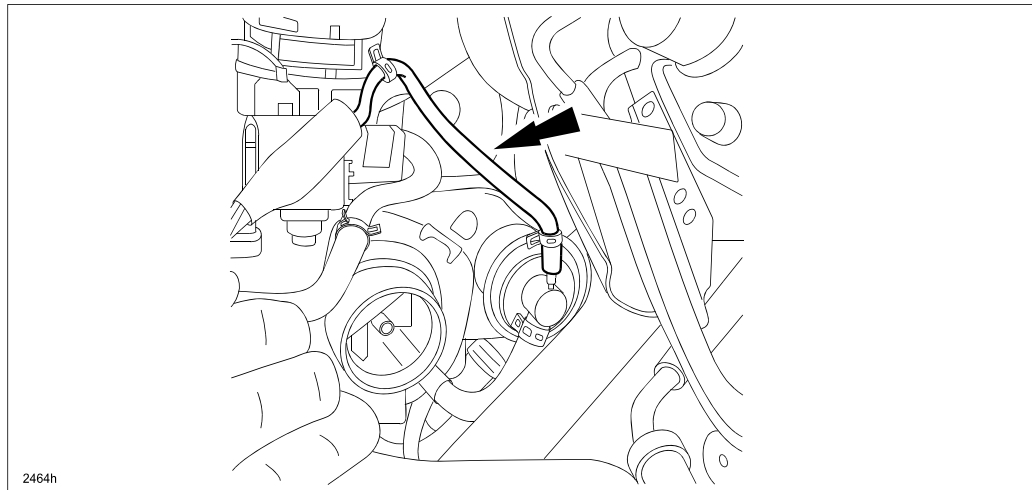

10. Remove the cylinder head cover.
a. Loosen the cylinder head cover bolt in the order shown below.

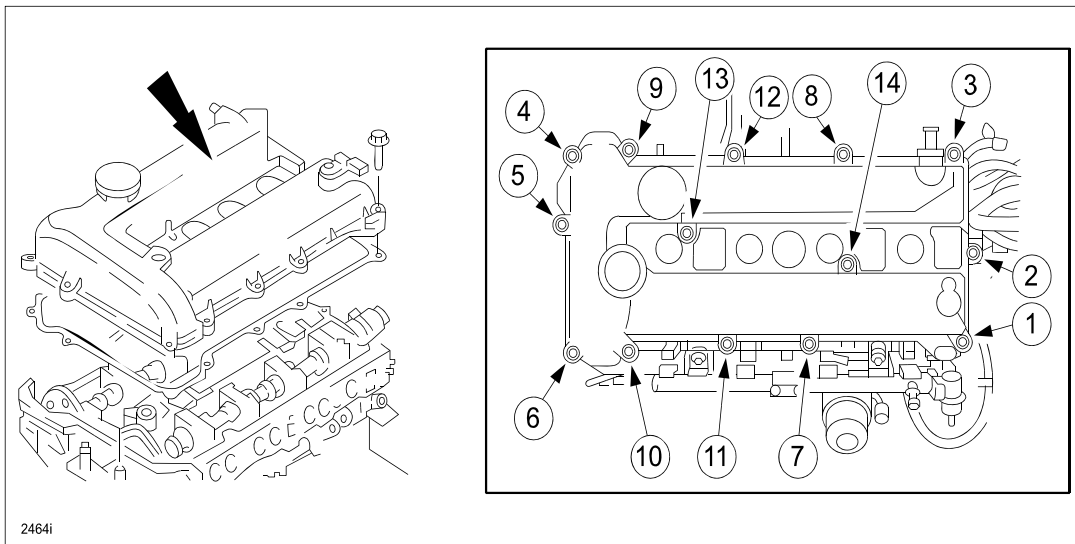

- b. Remove the cylinder head cover (A) with the ventilation hose (B).

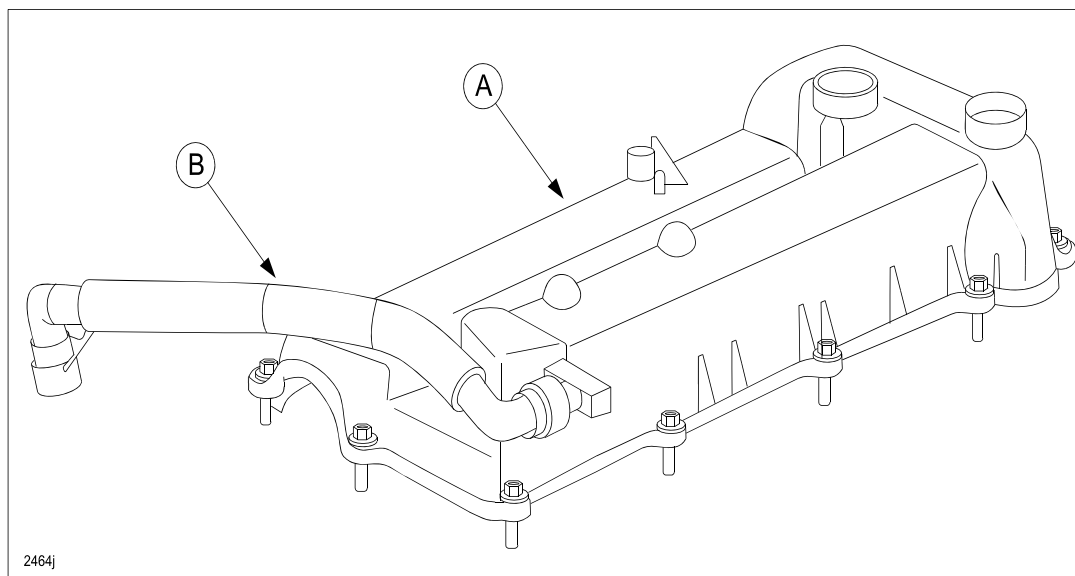

11. Remove the insulator bolt, then move the insulator (A) to create enough space to access the engine hanger bolt.
12. Remove the engine hanger bolt and engine hanger (B).

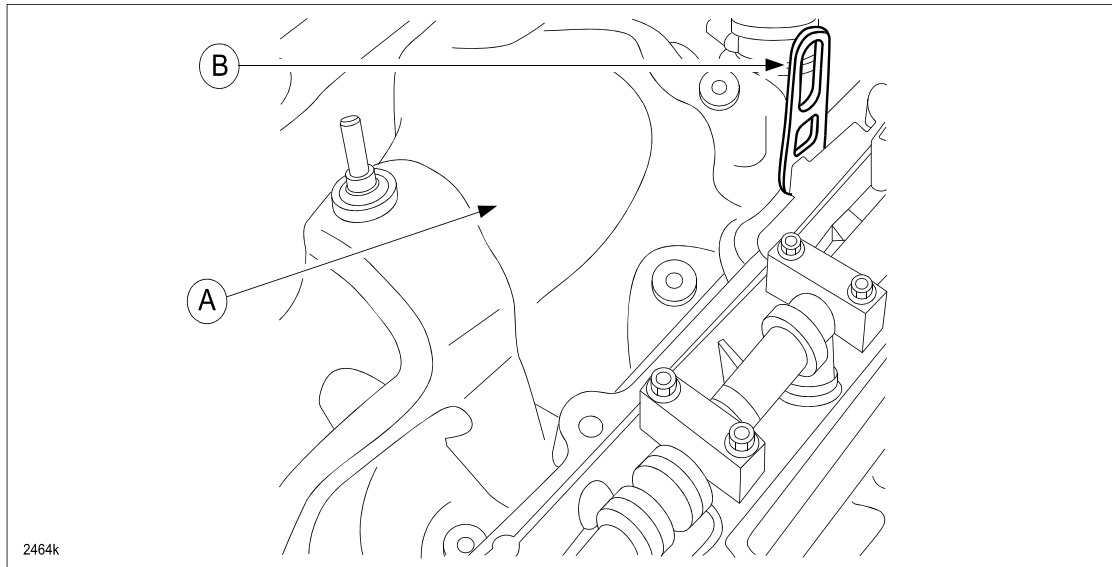

VENTILATION SET INSTALLATION:

1. Install new engine hanger.
Tightening Torque: 44-50 Nm
2. Install the insulator bolt.
Tightening Torque: 7.8-10.8 Nm
3. Clean up the cylinder head surface attached to the cylinder head cover.
4. Apply 5.0mm of silicone sealant to the spot shown below for cylinder head cover installation.

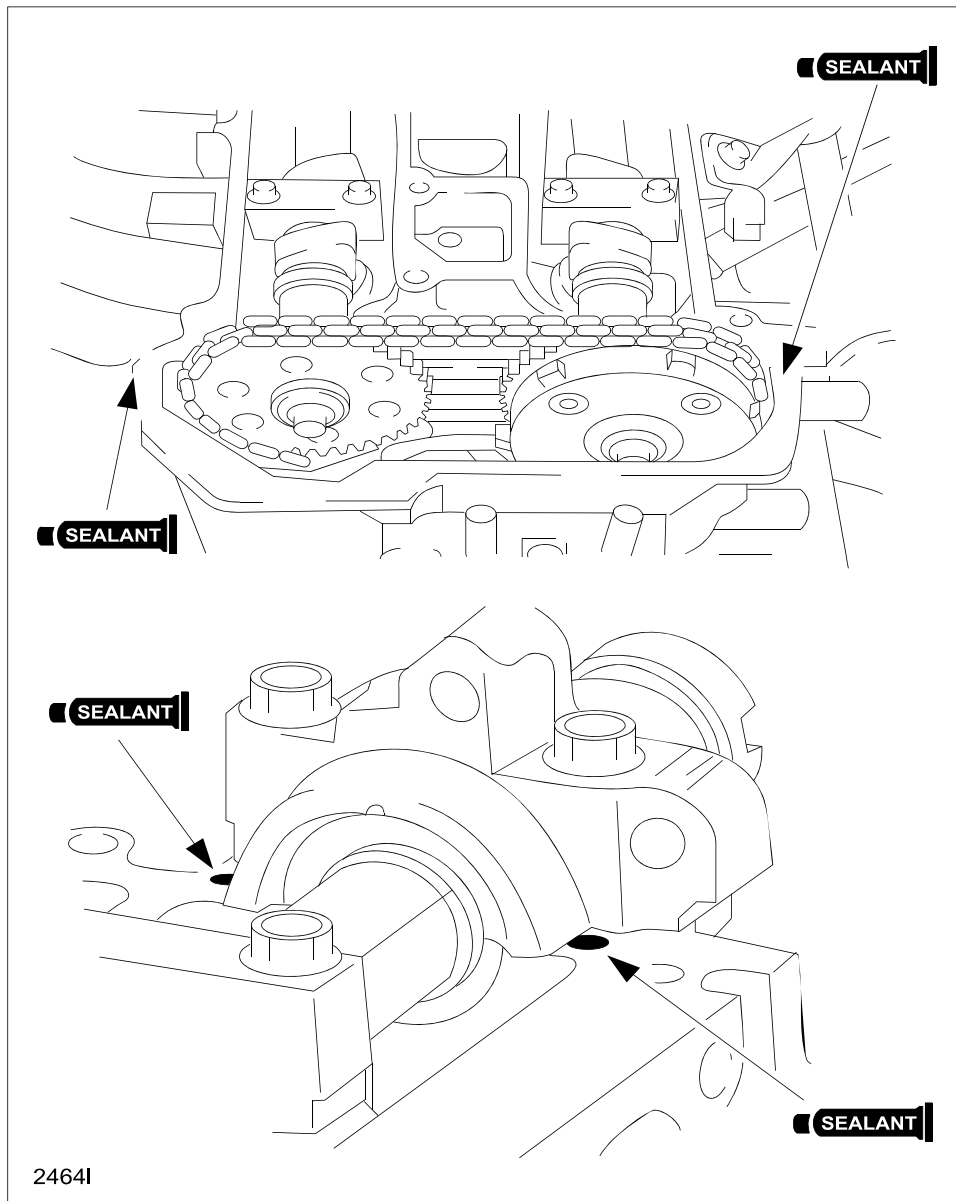

5. Install new cylinder head cover.
Tightening Torque: 8.0-9.5 Nm

NOTE: Fasten the cylinder head cover bolt in the order shown.

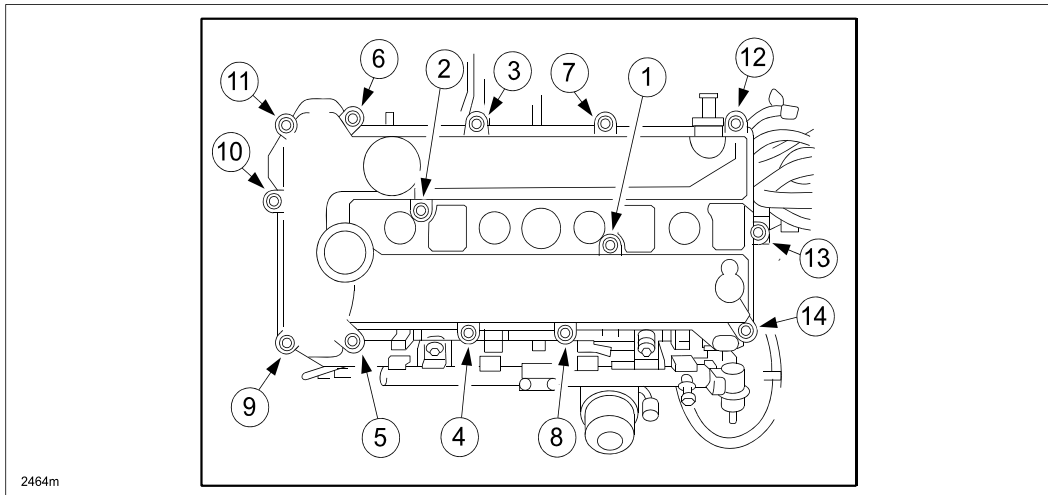

6. Install new vacuum hose (A) to the three-way solenoid valve (B).

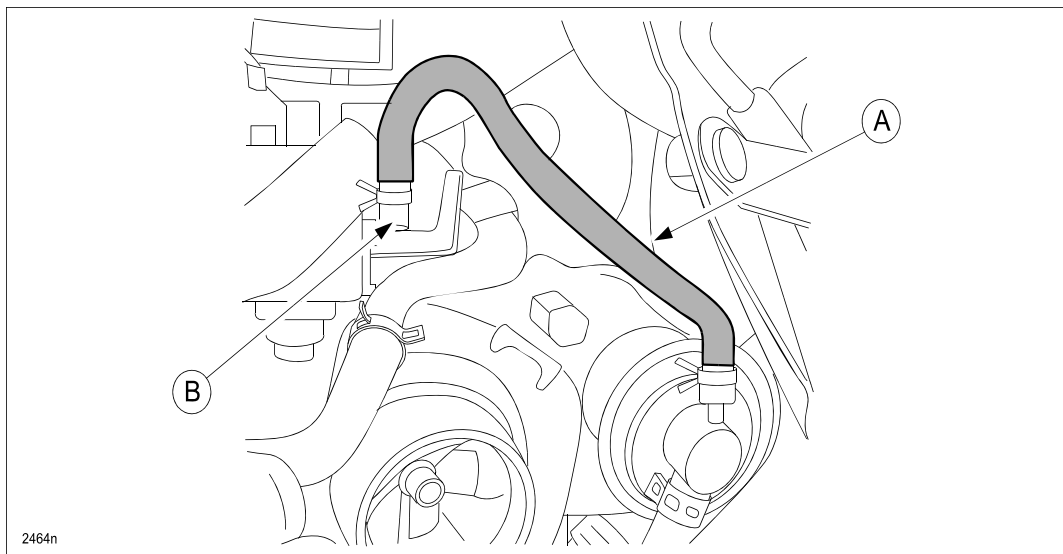

7. Install the hose (A) to new air pipe (B), then install new plug (C) and new vacuum hose (D).

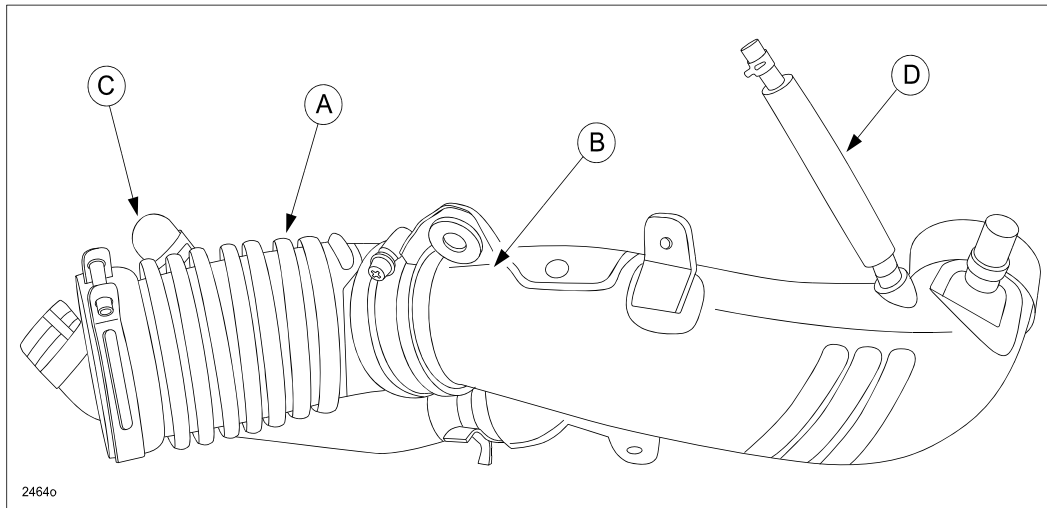

8. Install new air pipe.
Tightening Torque: 2.5-3.4 Nm

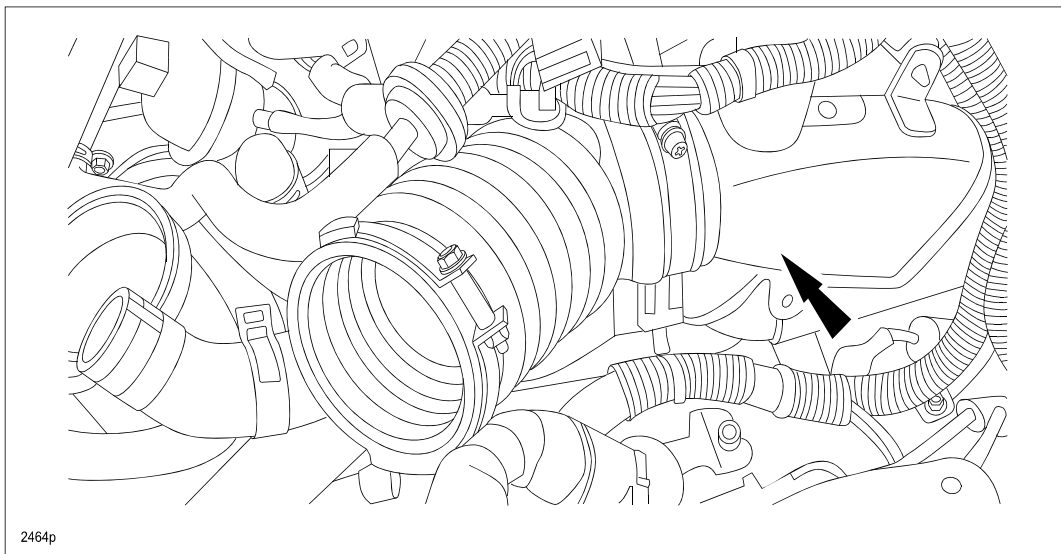

9. Install the vacuum hose (A) to the three-way solenoid valve and install the ventilation hose (B) to the cylinder head cover and the air pipe.

NOTE: After both hoses are securely installed, pull both levers (C) out.

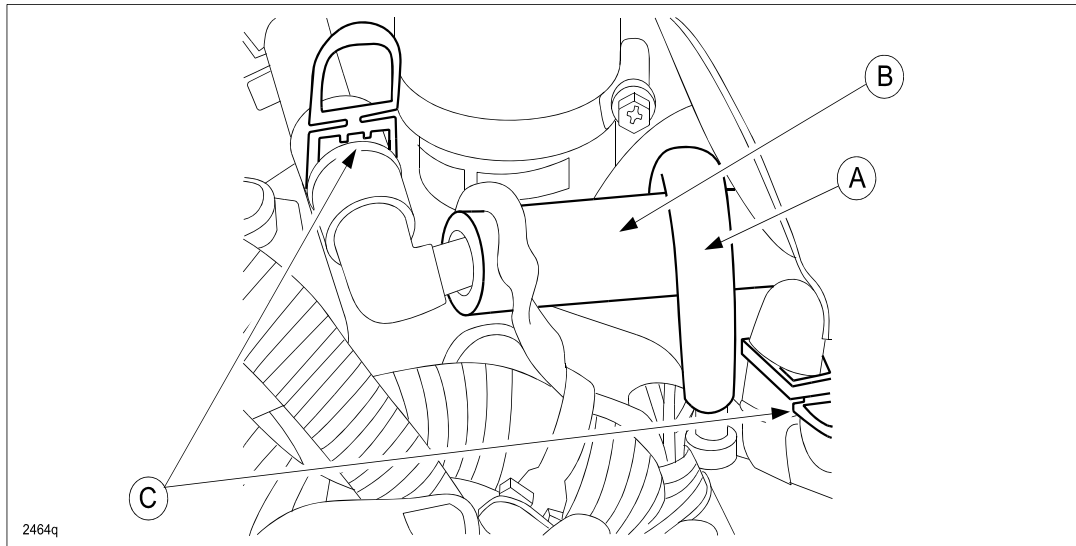

10. Install the intercooler.

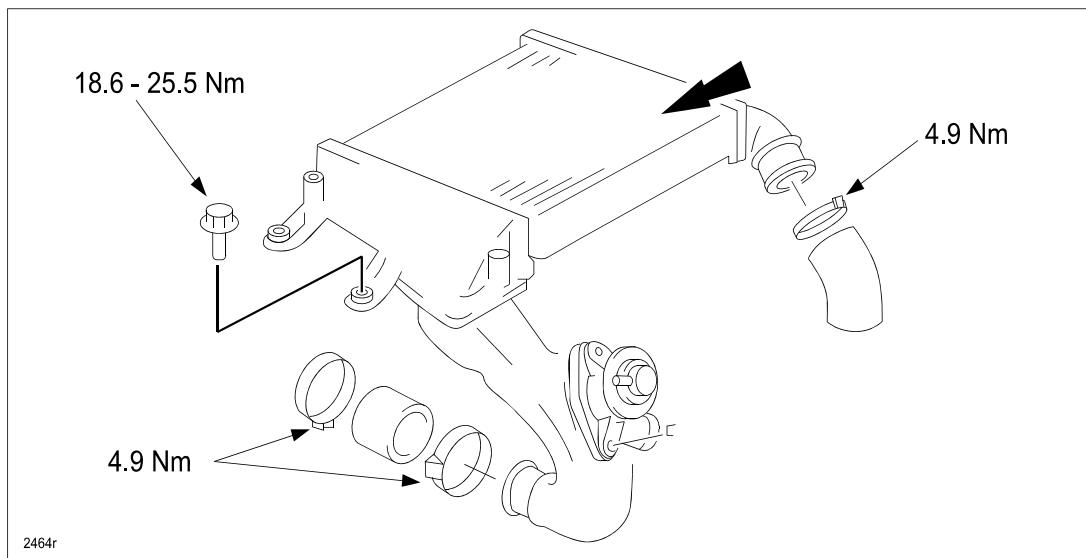

11. Install the battery tray, battery and battery clamp.
12. Install the air cleaner.

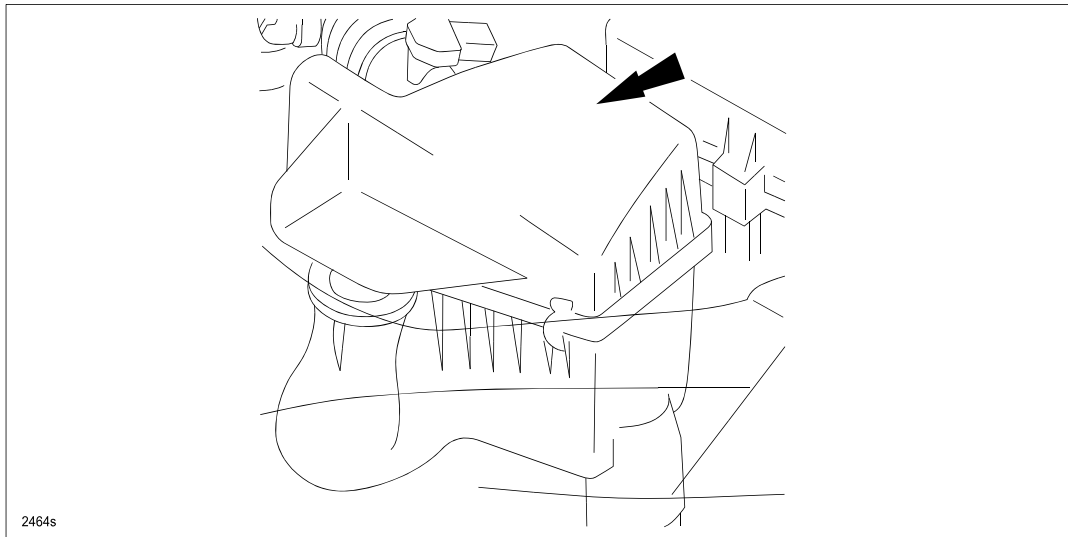

13. Install the intercooler cover.
14. Reconnect the negative battery cable.
15. Install the battery cover.
16. Re-enter the customer's pre-set radio stations.
17. Perform road test to ensure any remaining oil is burned off before returning the vehicle to the customer.

PART(S) INFORMATION

| Part Number | Description | Qty. | Notes |
|--------------|-----------------|------|-------------|
| L3Y1-13-S80B | Ventilation Set | 1 | CX-7 |
| L3Y2-13-S80B | Ventilation Set | 1 | Mazdaspeed3 |

WARRANTY INFORMATION

NOTE:

- This warranty information applies only to verified customer complaints on vehicles eligible for warranty repair.
- This repair is covered under Mazda New Vehicle Limited Warranty and Mazda Powertrain Limited Warranty. It may also be covered under California Emission Warranty, refer to Mazda Warranty Wizard to confirm coverage.
- If the turbocharger is diagnosed with impeller damage caused by contact with the housing (as described in the Inspection Procedure), this bulletin is not applicable.
- Additional diagnostic time cannot be claimed for this repair.
- The oil change program as described in the prior published service bulletin under the same subject, is no longer in effect.

| | |
|---------------------------------|--|
| Warranty Type | A |
| Symptom Code | 18 |
| Damage Code | 91 |
| Part Number Main Cause | L3Y1-13-S80B (CX-7) L3Y2-13-S80B (Mazdaspeed3) |
| Quantity | 1 |
| Operation Number / Labor Hours: | XXF4GARX / 1.3 (Ventilation Set, includes road test) |